

STEAMLOK ENGINEERING

SLFT - 25 (15 NB, 20 NB, 25 NB) Ball Float Steam Trap



SLFT-25 is an uniquely designed float trap in cast steel (WCB) with steam lock release.

SIZE

15 NB, 20 NB, 25NB

PIPE CONNECTIONS

Screwed : BSP, BSPT, NPT, Socket Weld
Flanged : ASA 150, ASA 300 Weld on

UNIQUE FEATURES

- Unique design Eco ball float steam trap.
- Uniquely designed with MOC cast steel (WCB).
- Self aligning steam lock release (SLR).
- Functional Test - 100% on steam.

DESIGN CONDITIONS

- Max. allowable pressure (PMA) - 51 bar (g)
- Max. allowable temperature (TMA) - 425°C
- Max. operating pressure (PMO) - 32 bar (g)
- Max. operating temperature (TMO) - 410 °C
- Max. differential pressure - ΔP_{max}
SLFT 25 - 4.5 - 4.5 bar(g)
SLFT 25 - 10 - 10 bar(g)
SLFT 25 - 13 - 13 bar (g)
SLFT 25 - 21 - 21 bar (g)
SLFT 25 - 32 - 32 bar (g)

CERTIFICATION

IBR approval / En10204 3.1

CONDENSATE DISCHARGE CAPACITY

MODEL	SIZE	DIFFERENTIAL PRESSURE (BAR)														
		0.5	1	1.5	2	2.5	3	3.5	4	4.5	5	5.5	6	6.5	7	7.5
SLFT25-4.5	15NB,20NB,25NB	540	700	755	885	949	1012	1106	1200	1315
SLFT25-10	15NB,20NB,25NB	240	325	380	430	470	510	540	570	598	628	652	675	690	705	725
SLFT25-13	15NB,20NB,25NB	130	165	190	225	245	265	265	300	315	330	347	363	374	385	394
SLFT25-21/32	15NB,20NB,25NB	122	155	172	190	207	225	241	258	270	287	298	308	328	350	364

MODEL	SIZE	DIFFERENTIAL PRESSURE (BAR)															
		8	8.5	9	9.5	10	10.5	11	11.5	12	12.5	13	17	21	25	29	32
SLFT25-4.5	15NB,20NB,25NB
SLFT25-10	15NB,20NB,25NB	745	768	790	800	810
SLFT25-13	15NB,20NB,25NB	403	417	430	442	455	463	471	480	488	496	505
SLFT25-21/32	15NB,20NB,25NB	378	387	395	403	410	417	425	431	437	442	447	461	473	481	487	491



(SLFT - 25) (15 NB, 20 NB, 25 NB) BALL FLOAT STEAM TRAP

CONSTRUCTION

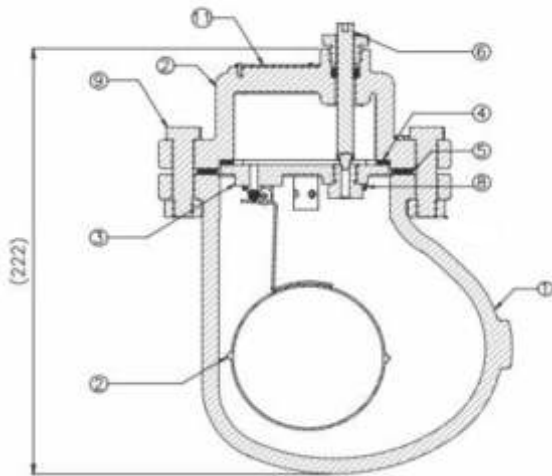

DIMENSIONS

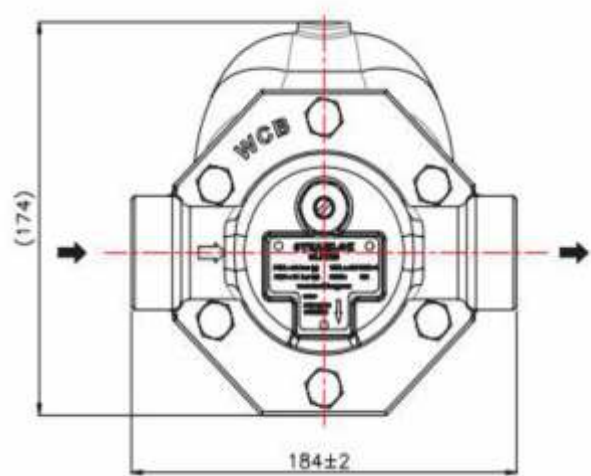

PART LIST

NO.	DESCRIPTION	MATERIAL	QTY
1	BODY	ASTM A216 GR.WCB	1
2	COVER		1
3	COVER SEAT PLATE	ASTM A351 GR.CF8	1
4	COVER GASKET	GRAPHITE WITH AISI 304	1
5	COVER SEAT PLATE GASKET	GRAPHITE WITH AISI 304	1
6	SLR UNIT	AISI 304	1
7	FLOAT ASSEMBLY	AISI 304	1
8	ALLEN BOLT 148	ASTM A193 GR.B7	4
9	ALLEN BOLT M10	ASTM A193 GR.B7	6
10	NAME PLATE	AISI 304	1

SPARE PARTS

- Valve Assembly with float (4.5 bar, 10 bar, 13 bar, 21 bar, 32 bar)
- Float Assembly
- Valve Assembly without float assembly (4.5 bar, 10 bar, 13 bar, 21 bar, 32 bar)
- Air Vent assembly
- SLR assembly
- Cover gasket (Set of 3)

INSTALLATION

- Trap must be installed in horizontal direction with arrow direction on nameplate pointing down.
- Inlet direction arrow on pipe end must be fitted at inlet of trap.
- Slow opening of isolation valve is recommended to avoid system shock.
- Ensure proper flushing of line before installation of trap.

HOW TO ORDER

Ex. SLFT25, Carbon Steel (WCB), Float Trap, 25NB, SCR-BSPT, 10 Bar, SLR, IBR.



Steamlok Engineering Private Limited

Factory : W75, S-Block, MIDC Bhosari, Pune (MH) 411 026, India

Email : sales@steamlokengineering.com

Web : www.steamlok.com | www.steamlok.co.in