



**SLPV - 25 is Seatless & Glandless piston valve in Cast Carbon Steel (WCB).
Maintenance free design suitable for varied applications.**

SIZE

15NB, 20NB, 25NB, 40NB, 50NB, 65NB, 80NB, 100NB, 125NB, 150NB, 200NB

PIPE CONNECTIONS

Flanged : ASA 150, ASA 300

UNIQUE FEATURES

- Wear & Erosion resistance for most of the fluids
- Unique sealing arrangement for extended life of Valve
- Class VI leakage Valve
- Use of Belleville washer to compensate thermal expansion

Size	#A150 (L)	#300 (L)	H
15NB	108	147	123
20NB	117	150	123
25NB	127	160	133
32NB	164	231	210
40NB	164	231	210
50NB	203	267	260
65NB	216	292	360
80NB	241	317	450
100NB	292	355	470
125NB	355	400	550
150NB	406	444	619
200NB	495	559	755

DESIGN CONDITIONS

END Connection	Max. Allowable Pressure (PMA) bar (g)	Max. Allowable Temp (TMA) °C
# ASA150	19.6	-29 to 38
	5.5	425
# ASA300	51.1	-29 to 38
	28.8	425

CERTIFICATION

IBR approval / En10204 3.1

INSTALLATION

SLPV - 25 can be installed both horizontally as well as vertically according to pipe line requirement.

- Valve is bi-directional but preferred to install valve as per arrow direction on the valve.
- Ensure proper flushing of line before installation.
- Periodic lubrication of valve is required for smooth functioning.

(SLPV - 25) Piston Valve

CONSTRUCTION

Size : 50 NB

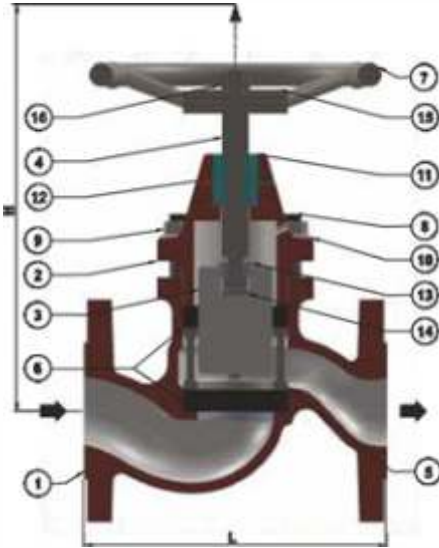

Size : 65 NB to 200 NB

- Body Seal Ring Assembly (Set of 2)
- Bonnet Seal Ring Assembly (Set of 2)
- Spindle (Set of 2)
- Split Nut (Set of 2)

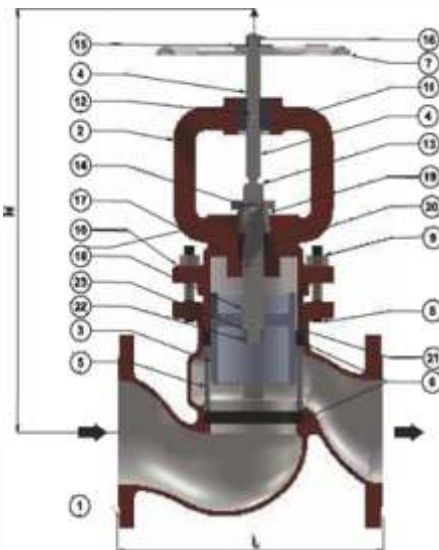

SPARE PARTS

- Body Seal Ring Assembly (set of 2)
- Bonnet Seal Ring Assembly (Set of 2)
- Spindle (set of 2)
- Split Nut (Set of 2)

Size : 50 NB

No.	Part Name	Material	Qty
1	Body	ASTM A 216 Gr. WCB	1
2	Bonnet	ASTM A 216 Gr. WCB	1
3	Piston	AISI 304	1
4	Spindle	AISI 420	1
5	Lantern Ring	ASTM A 743 GR.15	1
6	Body Seal Ring Assembly	Graphite + AISI 304	2
7	Hand Wheel	MS	1
8	Stud	ASTM A 193 Gr. B7	*
9	Nut	ASTM A 194 Gr. 2H	*
10	Belleville Washer	Spring Steel 50Cr. V4	*
11	Spindle Bush	AL Bronze	1
12	Bush Retainer	Spring Steel	2
13	Split Nut	Brass	1
14	Thrust Disc	AISI 420 + H.T.	1
15	Name Plate	AISI 304	1
16	Hand Wheel Nut	AISI 304	1

Size : 65 NB to 200 NB

No.	Part Name	Material	Qty
1to16	Same as 50NB		1
17	Stem	AISI 304	1
18	Backseat Bush	AISI 304	1
19	Gland Nut	ASTM A743 GR. CA 40	1
20	Bonnet Ring Seal Assembly	Graphite + AISI 304	1
21	Bonnet Lower Sealing Ring	Graphite	1
22	Stem Nut	AISI 304	1
23	Stem Washer	AISI 304	1

* For 50, 65NB - stud, nut- 4no.,
Belleville washer - 8no. 80, 100NB - stud, nut - 6no.,
Belleville washer - 12no. 125, 150, 200NB - stud, nut - 8no.,
Belleville washer - 16no.

BONNET MOC FOR 65NB TO 200NB - WCB

HOW TO ORDER

Ex. SLPV - 25 Cast Steel Piston Valve,
50 NB flange ASA150, IBR



Steamlok Engineering Private Limited

Factory : W75, S-Block, MIDC Bhosari, Pune (MH) 411 026, India

Email : sales@steamlokengineering.com

Web : www.steamlok.com | www.steamlok.co.in