



SLPV - 35 is Seatless & Glandless piston valve in forged carbon steel construction. Maintenance free design suitable for varied applications.

SIZE

15 NB, 20 NB, 25 NB, 32 NB, 40 NB

PIPE CONNECTIONS

Screwed : BSP, BSPT, NPT, Socket Weld

Flanged : ASA 150, ASA 300 (Weld on)

UNIQUE FEATURES

- Heat resistant hand wheel
- Wear & Erosion resistance for most of the fluids
- Unique sealing arrangement for extended life of Valve
- Class VI leakage Valve
- Use of Belleville washer to compensate thermal expansion

DIMENSIONS

Size	SCR/SW (L)	#150 (L)	#300 (L)	H
15 NB	107	219	233	150
20 NB	107	219	239	150
25 NB	116	232	250	174
32 NB	159	271	283	238
40NB	159	285	300	238

DESIGN CONDITIONS

END Connection	Max. Allowable Pressure (PMA) bar (g)	Max.m Allowable Temp (TMA)
BSP	20	425
BSPT/NPT	31.6	425
Socket Weld	76.4	425
# ASA150	13.8	200
# ASA300	34.7	400

CERTIFICATION

IBR approval / En 10204 3.1

INSTALLATION

- SLPV - 35 can be installed both horizontally as well as vertically according to pipe line requirement.
- Valve is bi-directional but preferred to install valve as per arrow direction on the valve.
- Ensure proper flushing of line before installation.
- Periodic lubrication of valve is required for smooth functioning.

(SLPV - 35) PISTON VALVE

CONSTRUCTION

Size : 15NB, 20NB, 25NB

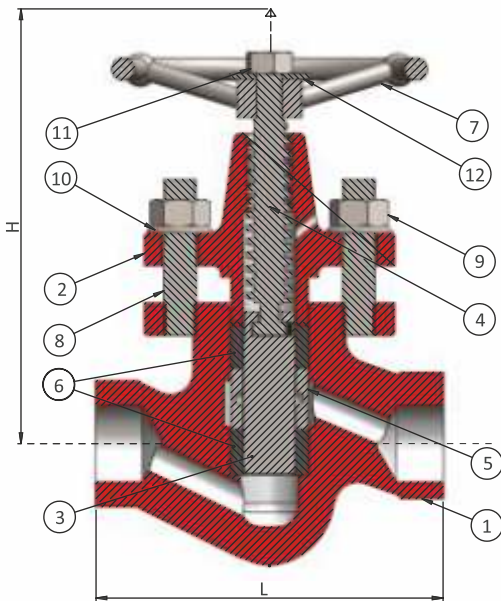

Size : 32NB & 40NB

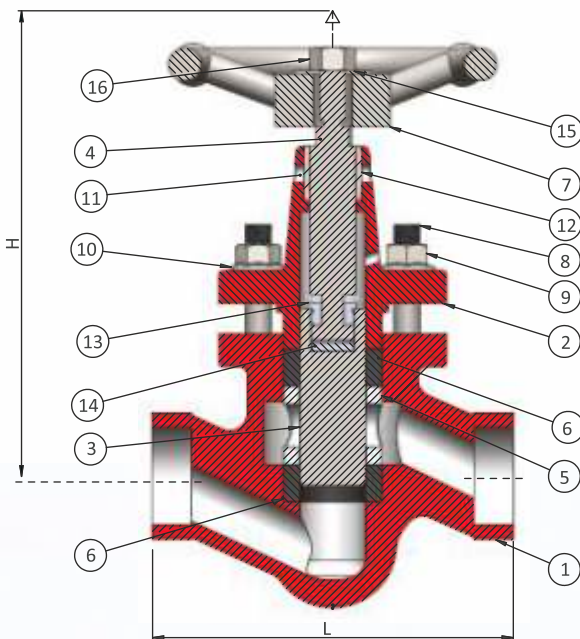

HOW TO ORDER

Ex. SLPV - 35 forged Carbon steel piston valve,
15NB socket weld connection, IBR.

PART LIST

Size : 15NB, 20NB, 25NB

No.	Part Name	Material	Qty
1	Body	ASTM A 105	1
2	Bonnet	ASTM A 105	1
3	Piston	AISI 304	1
4	Spindle	AISI 420	1
5	Lantern Ring	AISI 420	1
6	Seal Ring Assembly	Graphite + AISI 304	2
7	Hand Wheel	Fiber Glass	1
8	Stud	ASTM A 193 Gr. B7	2
9	Nut	ASTM A 194 Gr. 2H	2
10	Belleville Washer	Spring Steel 50Cr. V4	4
11	Hand Wheel Lock Nut	AISI 304	1
12	Name plate	AISI 304	1

* Note : For 25NB, Item no. 8,9,10 required twice the above mentioned quantity.

Size : 32NB & 40NB

No.	Part Name	Material	Qty
1-7	Same as 15NB, 20NB, 25NB		
8	Stud	ASTM A 193 Gr. B7	4
9	Nut	ASTM A 194 Gr. 2H	4
10	Belleville Washer	Spring Steel 50Cr. V4	8
11	Spindle Bush	AL Bronze	1
12	Bush Retainer	Spring Steel	1
13	Split Nut	Brass	1
14	Thrust Disc	AISI 420 + H.T.	1
15	Name plate	AISI 304	1
16	Hand wheel Nut	AISI 304	1

SPARE PARTS

- Seal ring Assembly (set of 5)
- Spindle (set of 5)
- Split nut (Set of 5)



Steamlok Engineering Private Limited

Factory : W75, S-Block, MIDC Bhosari, Pune (MH) 411 026, India

Email : sales@steamlokengineering.com

Web : www.steamlok.com | www.steamlok.co.in